



Öl-Luft-Kühler

Oil-Air-Cooler



BerLiTech
POWER TRANSMISSION

Öl-Luft-Kühler

Oil-Air-Cooler

Öl-Luft-Kühler

Oil-Air-Cooler

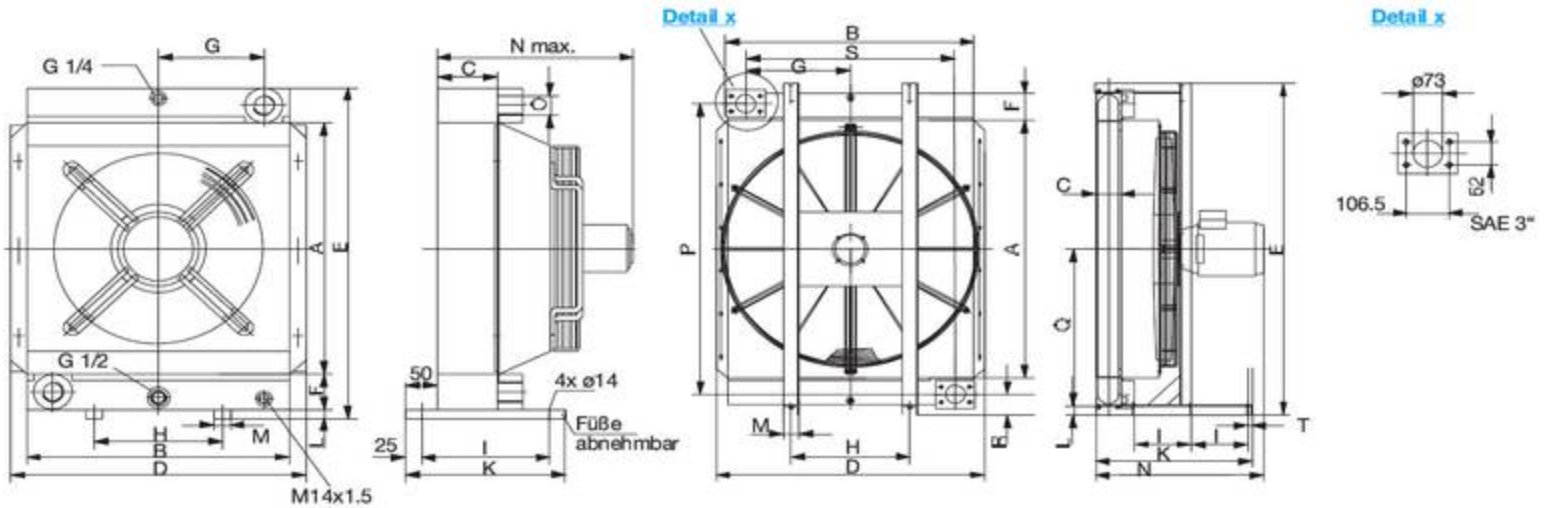

Abmessungen / Bezeichnungen

Bez. / Description	T1	T2	T3	T4	T5 (T5K)	T6	T7	T8	T9	T10	T11
Leistung / Power KW	1-5	3-10	8-15	10-20	15-25	20-35	25-40	35-75	60-120	85-180	120-260
A	200	300	400	400	550	650	800	800	1050	1050	1200
B	191	302	396	396	411	557	557	651	915	915	1206
C	63	63	63	94	94 (63)	94	94	140	94	113	140
D	248	355	451	451	466	607	608	722	995	995	1276
E	315	415	515	535	690	790	940	960	1352	1352	1520
F	50	50	50	60	60	60	60	70	110	110	110
G	65	115	160	160	165	235	235	280	390	390	532
H	80	150	200	200	200	310	310	400	440	440	525
I	150	200	200	250	250	250	250	250	215	215	210
K	200	250	250	300	300	300	300	300	580	580	750
L	15	15	15	15	20	20	20	20	40	40	50
M	25	25	25	25	30	50	50	50	65	65	100
N max.	175	370	400	430	440 (410)	ca. 450	ca. 450	ca. 590	ca. 650	ca. 790	ca. 900
O	G1	G1	G1	G1 1/4	G1 1/4	G1 1/4	G1 1/4	G1 1/2			
P									1182	1182	1332
Q									635	635	710
R									91	91	94
S									780	780	1064
T									15	15	20

Alle Kühler werden einer statischen Druckprüfung nach DIN 50104 unterzogen
 All cooler are subjected to a pressure test according to DIN 50104

Öl-Luft-Kühler Oil-Air-Cooler

Schnellauslegung für Hydraulikanwendungen

Quick-Selection for hydraulic applications

Mit Hilfe der folgenden Tabelle können Sie auf schnellstem Weg einen Kühler auslegen. Dabei wurde angenommen, dass die maximale Öltemperatur in Hydraulikanwendungen 70°C und in Schmierölanwendungen 110°C nicht übersteigt.

Use the following table to select your cooler. It was assumed that the maximum oil temperature does not exceed 70 ° C in hydraulic applications and 110°C in lubricating oil applications.

Wenn die abzuführende Kühlleistung nicht bekannt ist, können die folgenden Werte zugrundegelegt werden:

If the cooling performance is not known, the following values can be used:

**Bau- oder Landmaschinen
elektromotorisch angetriebene, hydraulische Pumpen**

Agricultural machinery
Driven by electric motors, hydraulic pumps

1/3 der Leistung des Dieselmotors

1/3 der Motorleistung

1/3 of the power of the diesel engine

1/3 of engine power

für Hydraulikanwendungen

for hydraulic applications

Kühlleistung in KW bei 30°C Umgebungstemperatur						Cooling capacity in kW at 30 ° C ambient temperature						
l/min	T1	T2	T3	T4	T5K	T5	T6	T7	T8	T9	T10	T11
10	2	4	6									
20	3	6	8	8	15							
30	4	7	10	11	17							
50	5	8	12	13	18	21	28	32	39			
75	5.5	9	13	15	20	23	30	34	42	61		
100		10	14	16	21	24	32	36	44	69	112	
150			16	18	23	26	34	38	48	81	128	172
200						28	35	40	50	90	140	196
250									51	96	148	212
300										100	156	228
400										110	168	248
500										118	180	266
600												280

Kühlleistung in KW bei 40°C Umgebungstemperatur						Cooling capacity in kW at 40 ° C ambient temperature						
l/min	T1	T2	T3	T4	T5K	T5	T6	T7	T8	T9	T10	T11
10	1.5	3	5									
20	2.5	4	6	6	11							
30	3	5	7	8.5	13							
50	3.5	6	9	10	14	16	20	24	28			
75		7	10	11	15	17	23	26	31	46	60	
100		8	11	12	16	18	24	27	33	52	84	131
150			12	13	17	20	25	29	36	61	96	147
200						21	26	30	37	68	105	159
250									38	72	111	171
300										75	117	186
400										83	126	200
500										89	135	210
600												

Öl-Luft-Kühler

Oil-Air-Cooler

Schnellauslegung für Schmierölanwendungen

Quick-Selection for lubricating oil applications

Mit Hilfe der folgenden Tabelle können Sie auf schnellstem Weg einen Kühler auslegen. Dabei wurde angenommen, dass die maximale Öltemperatur in Hydraulikanwendungen 70°C und in Schmierölanwendungen 110°C nicht übersteigt.

Use the following table to select your cooler. It was assumed that the maximum oil temperature does not exceed 70 °C in hydraulic applications and 110°C in lubricating oil applications.

Wenn die abzuführende Kühlleistung nicht bekannt ist, können die folgenden Werte zugrundegelegt werden:

If the cooling performance is not known, the following values can be used:

Bau- oder Landmaschinen
elektromotorisch angetriebene, hydraulische Pumpen

1/3 der Leistung des Dieselmotors
1/3 der Motorleistung

Agricultural machinery
Driven by electric motors, hydraulic pumps

1/3 of the power of the diesel engine
1/3 of engine power

für Schmieranwendungen

for lubricating oil applications

Kühlleistung in KW bei 30°C Umgebungstemperatur						Cooling capacity in kW at 30 ° C ambient temperature						
l/min	T1	T2	T3	T4	T5K	T5	T6	T7	T8	T9	T10	T11
10	4	8	12									
20	6.5	11	16	16	30							
30	8	14	19	22	34	35						
50	9.5	17	23	26	37	42	55	64	78			
75	10.5	19	26	30	40	46	60	69	83	122		
100		21	28	32	42	49	64	72	88	138	224	
150			32	36	46	53	67	77	96	162	256	344
200						56	70	80	100	180	280	392
250									102	192	296	424
300										200	312	456
400										220	336	496
500										236	360	532
600												560

Kühlleistung in KW bei 40°C Umgebungstemperatur						Cooling capacity in kW at 40 ° C ambient temperature						
l/min	T1	T2	T3	T4	T5K	T5	T6	T7	T8	T9	T10	T11
10	3.5	7	11									
20	5.5	10	14	14	27							
30	7	12	17	20	30	31						
50	8	14	20	23	32	37	48	56	69			
75	9	16	22	27	35	40	53	60	73	107		
100		18	24	29	37	43	55	63	77	121	196	
150			28	32	40	46	59	67	84	142	224	301
200						49	62	70	88	158	245	343
250									90	168	259	371
300										175	273	399
400										193	294	434
500										207	315	466
600												490

Öl-Luft-Kühler

Oil-Air-Cooler

Übersicht Standardkühler

overview standard cooler

Typ type	Nummer number	Ø Ventilator Ø Fan	Ventilator- drehzahl Fan rotation U/min - RPM	Schallpegel sound level db(A)	Spannung voltage (V)	Leistungs- aufnahme Power	Füllinhalt (L) Filling contents	Druck pressure	Gewicht (KG) weight
T1	T00.901	167	3250	71	12	0.08	1	26	6.7
T1	T00.902	167	3250	71	24	0.08	1	26	6.7
T1	T00.903	170	2750	64	230/400	0.05	1	26	7.1
T2	T02.901	255	2600	74	12	0.15	1.9	26	15.6
T2	T02.902	255	2600	72	24	0.15	1.9	26	15.6
T2	T02.903	250	3000	75	230/400	0.25	1.9	26	15.6
T3	T03.901	350	2950	76	12	0.5	2.9	26	23
T3	T03.902	350	2950	78	24	0.25	2.9	26	23
T3	T03.903	380	1500	75	230/400	0.37	2.9	26	23
T4	T04.901	350	2950	77	12	0.2	5.2	26	28.8
T4	T04.902	350	2950	78	24	0.25	5.2	26	28.8
T4	T04.903	380	1500	77	230/400	0.37	5.2	26	28.8
T5	T05.901	385	3100	79	12	0.27	6.3	26	38
T5	T05.902	385	3100	79	24	0.24	6.3	26	38
T5	T05.903	450	1500	77	230/400	0.37	6.3	26	38
T5K	T15.904	450	1500	77	230/400	0.37	6.3	26	38
T6	T06.902	2x305	3100	81	24	2x0,27	9.4	26	49
T6	T06.903	500	1500	79	230/400	0.55	9.4	26	49
T7	T07.903	500	1500	79	230/400	0.55	10.6	26	54
T8	T08.903	630	1000	79	230/400	1.1	17.7	26	89
T9	T09.903	900	1000	88	230/400	2.2	25	10	190
T10	T10.903	900	1500	98	400/690	5.5	31	10	200
T11	T11.903	1000	1500	100	400/690	11	55	10	ca.290

Drehstrommotor / Three-phase motor:

T2-T9: B14 kleiner Flansch / small flange

T10-T11:B5

Werkstoffe

Kühlerblock	Aluminium
Ventilator	Kunststoff
Lüfterhaube	Stahl verzinkt
Schutzgitter	Stahl verzinkt
Füße	Stahl Farbanstrich
Motorhalterung	Stahl Farbanstrich

Materials

radiator core	aluminum
fan	plastic
fan cowl	galvanized steel
guard	galvanized steel
feet	steel painted
engine bracket	steel painted

Sondertypen auf Anfrage lieferbar

Other types available on request

Öl-Luft-Kühler

Oil-Air-Cooler

Spezifische Kühlleistung T1-T8

Specific Cooling Performance T1-T8

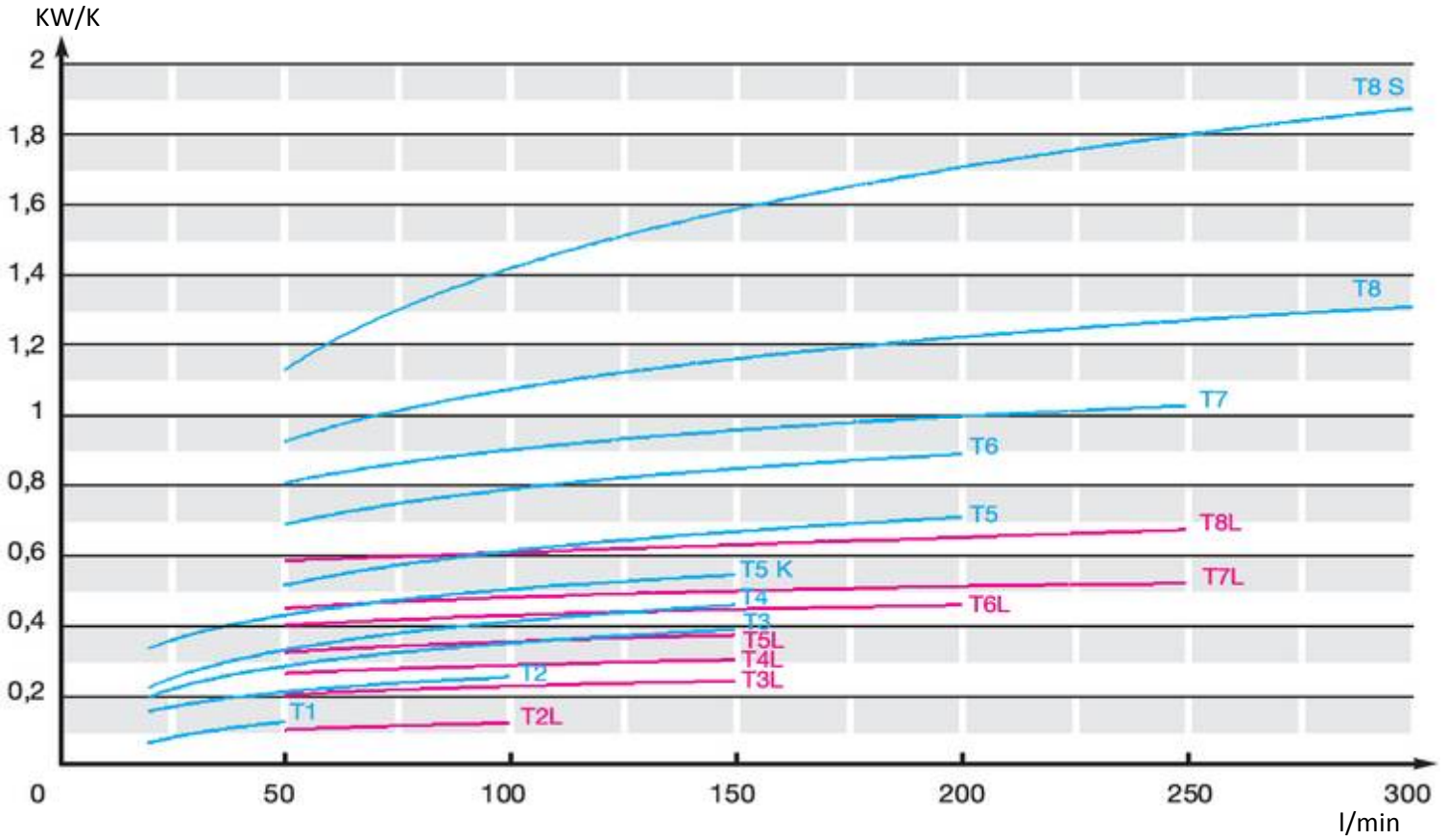

Druckverlust T1-T8

pressure loss T1-T8

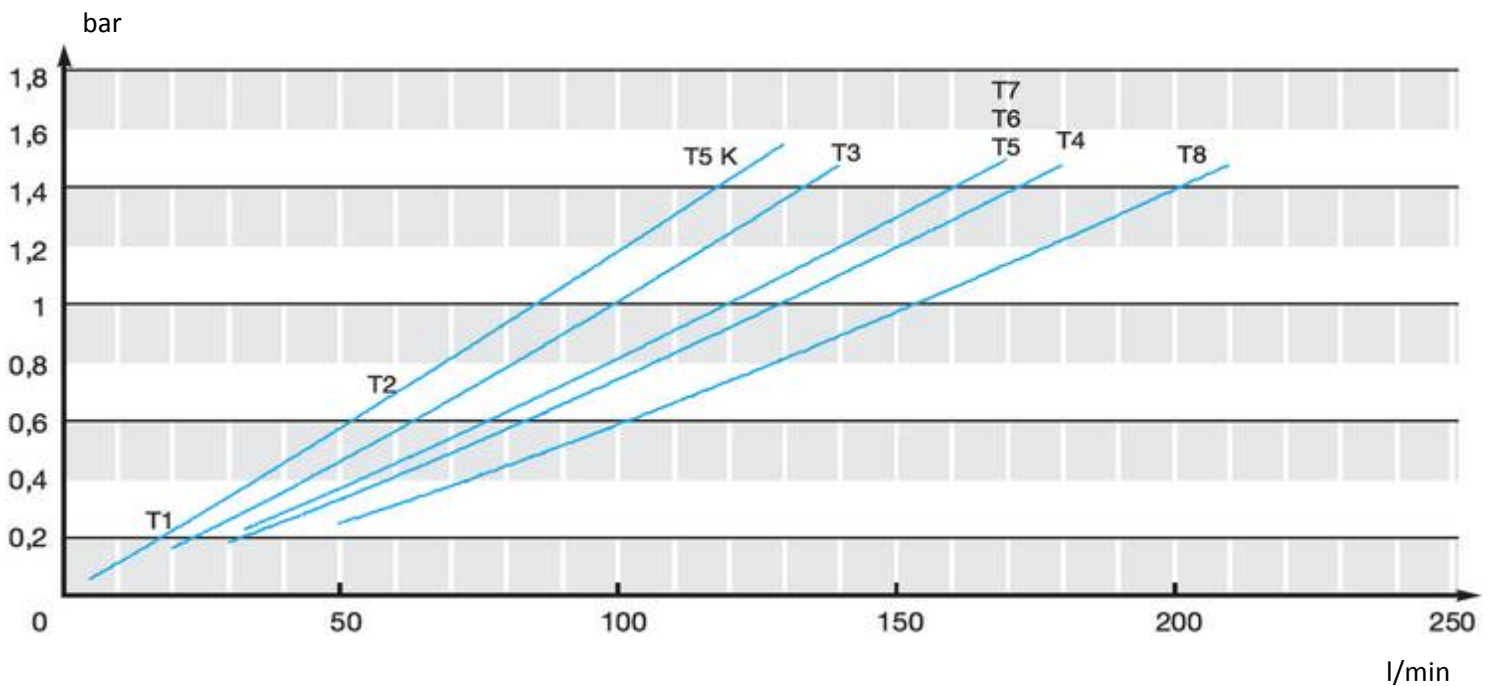

Werte gelten für Viskosität 30 cSt

Values are valid for viscosity 30 cSt

Öl-Luft-Kühler

Oil-Air-Cooler

Spezifische Kühlleistung T9-T11

Specific Cooling Performance T9-T11

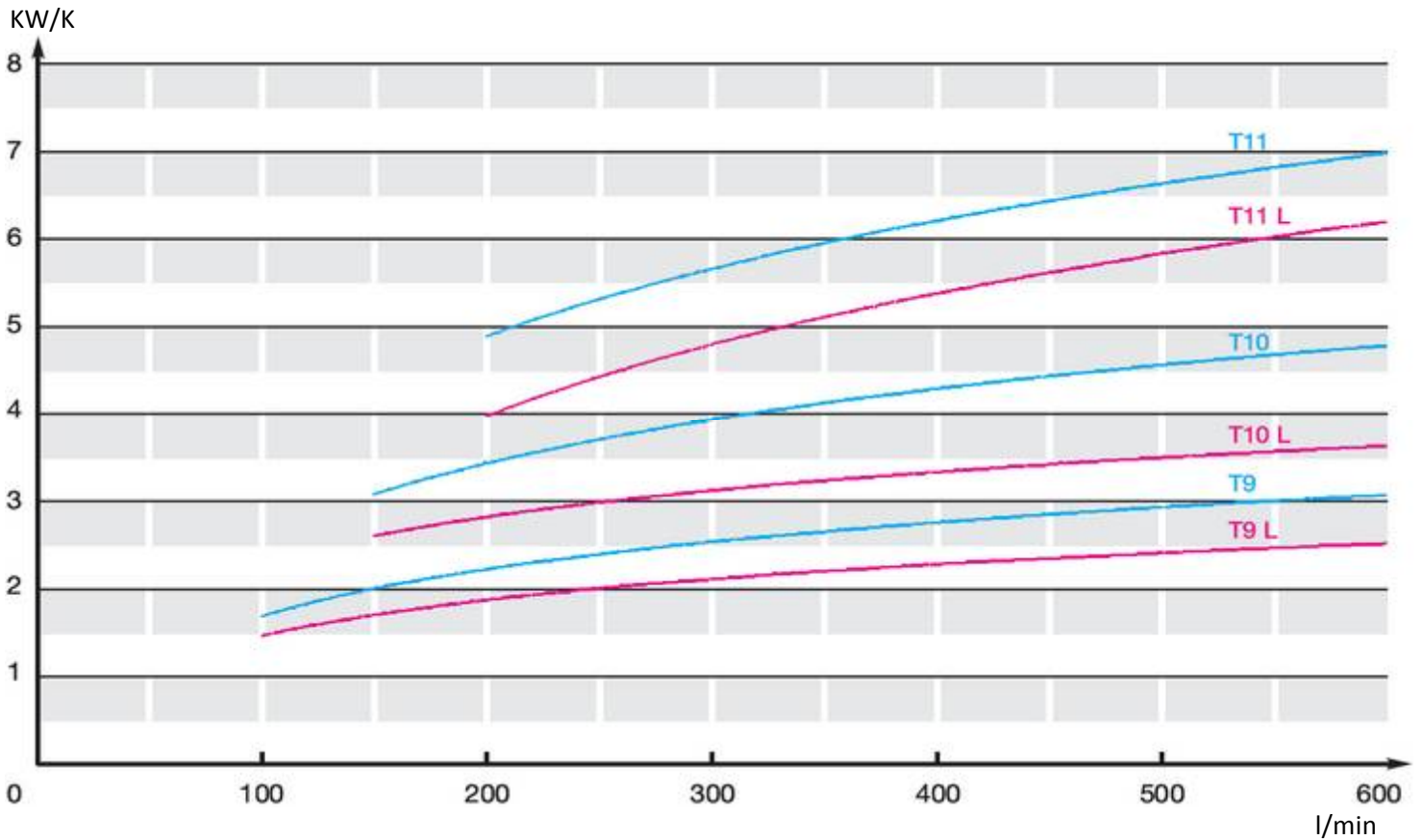

Druckverlust T9-T11

pressure loss T9-T11

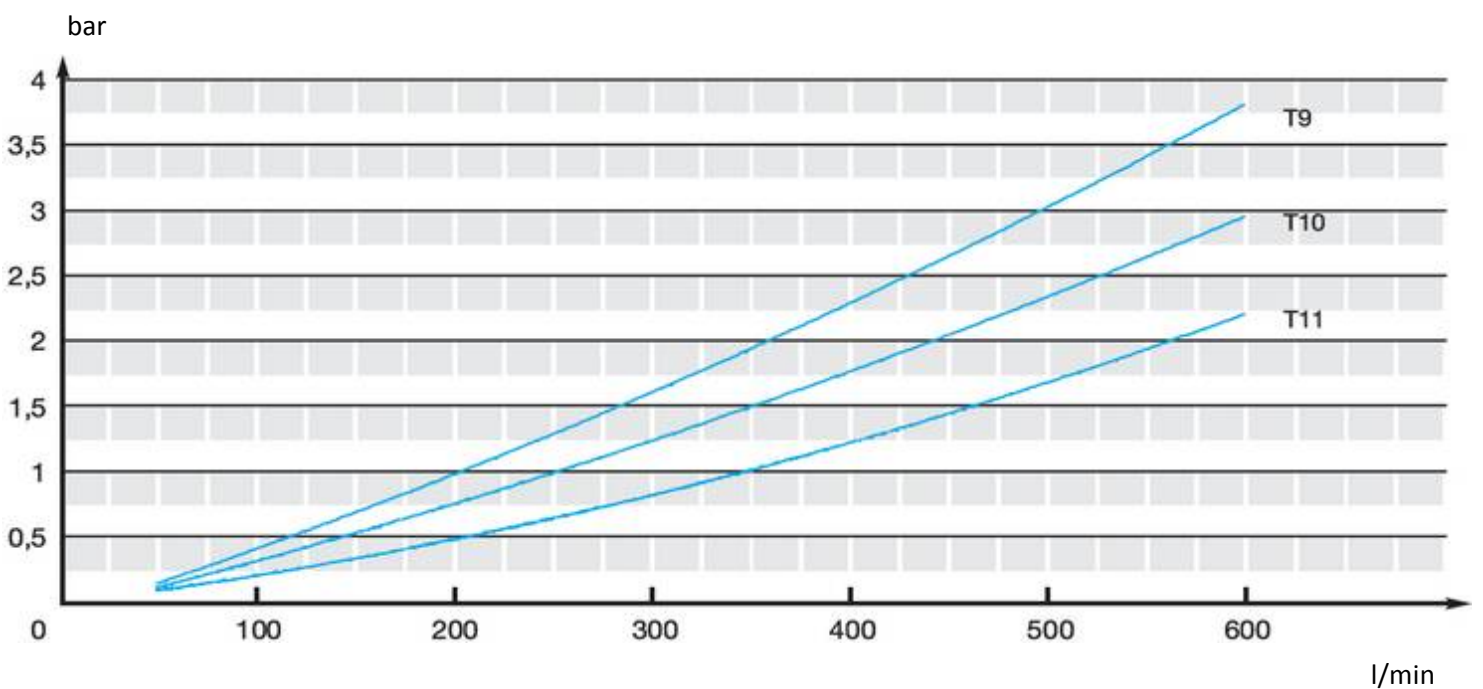

Werte gelten für Viskosität 30 cSt

Values are valid for viscosity 30 cSt